

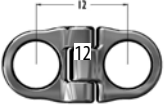



# Hinge Plate

**The Hinge Pediatric Plating System** is an articulated plate used to guide growth and deformity correction. Indicated in children and adolescents with deformities such as genu varum and genu valgum, it includes one plate and two screws. By fixing the plate on either side of the physal plate, axial growth can be controlled and angular deformity corrected.

Plates and screws are manufactured in medical grade Stainless Steel (316L as per ASTM F138). The plate is provided in three different sizes with distances between the anchoring points of the screws of 12, 16 and 20mm. The screws are provided in three different lengths of 25, 30 and 35mm.

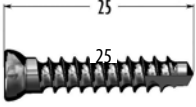
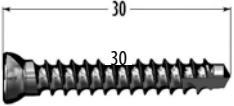
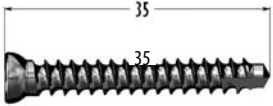
Cat. #	Implant Components
HPI012	Small Hinge plate 12 mm 
HPI016	Medium Hinge Plate 16 mm 
HPI020	Large Hinge Plate 20 mm 
HPS025	Screw 4.5 x 25 mm 
HPS030	Screw 4.5 x 30 mm 
HPS035	Screw 4.5 x 35 mm 

## Hinge Plate

by Pega Medical

Developed in collaboration with:

Daniel Green, MD, FACS  
 Pediatric Orthopedic and  
 Scoliosis Services  
 Hospital for Special Surgery, NY, NY USA



# Pega Medical

1105 Autoroute Chomedey, Laval, Quebec CANADA H7W 5J8  
Phone: 450-688-5144 ■ Fax: 450-688-1977  
info@pegamedical.com  
www.pegamedical.com

© 2009 Pega Medical, Inc.

Distributed by

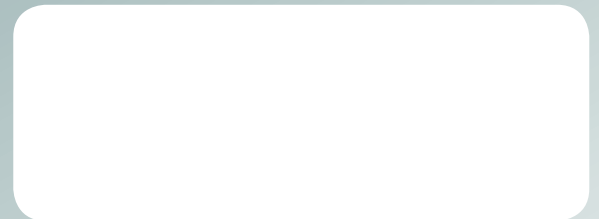



Pega Medical



## STONEHENGE

*From the Old English words «stān» meaning «stone» and «hencg» meaning «hinge».*



## HINGE PLATE

*From the modern orthopedic concept of «Guided Growth» comes a jointed device with a pivot at which angular correction occurs.*

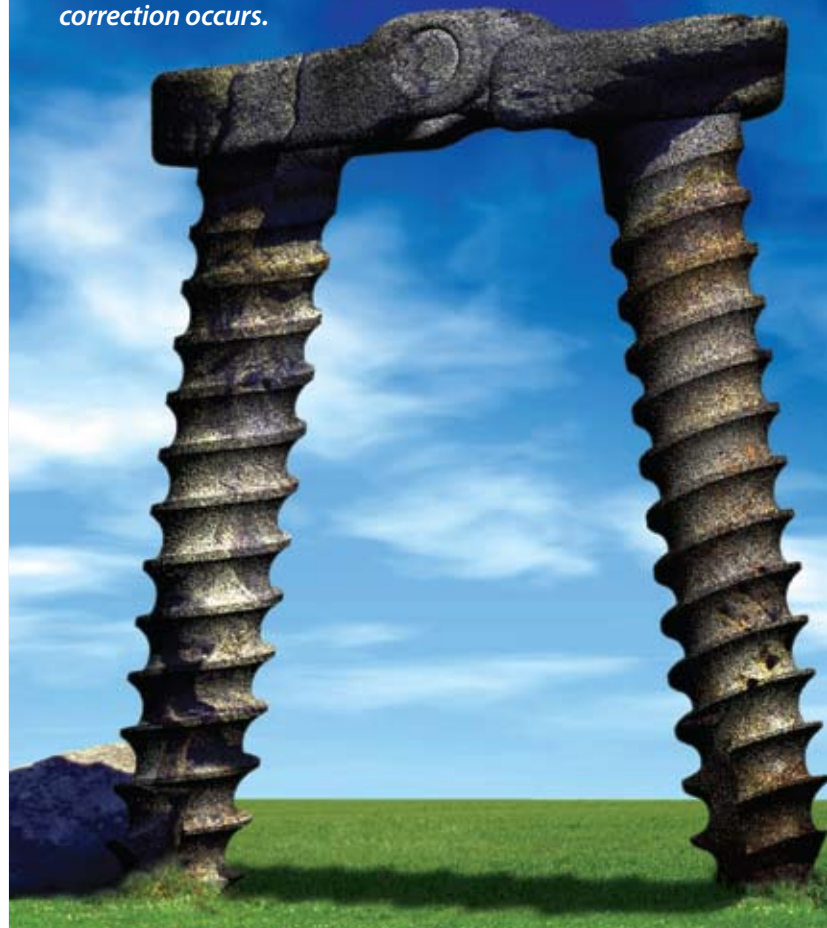

SURGICAL TECHNIQUE

For the treatment of pediatric angular deformities on long bones of arms and legs.

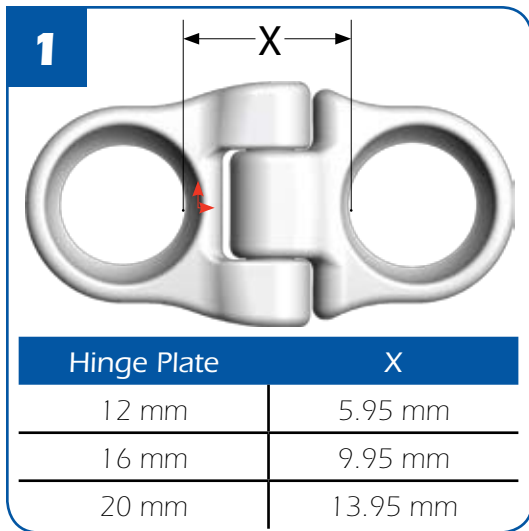

### Pre-Op Planning:

A careful preoperative planning and radiological analysis should be used to define the CORA, plane, direction and magnitude of the deformity intended to correct.

### Hinge Plate and Screws Selection:

The device is selected according to the patient's growth plate height and location to prevent invasion or damage of the physis. These variables define the plate size and screw length.

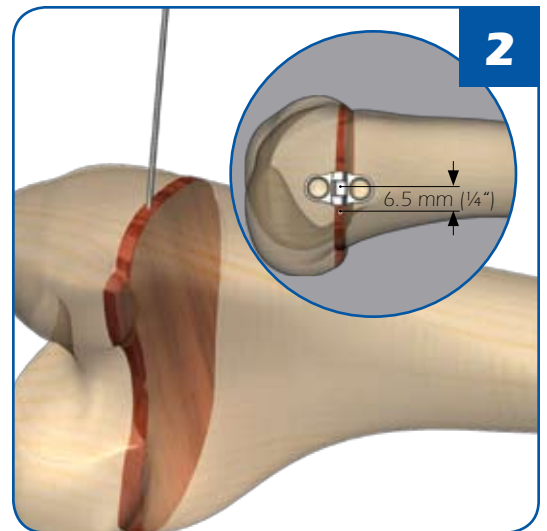

Initial location for placement of the Hinge Plate is achieved by inserting a guiding K-wire to localize the growth plate under fluoroscopic imaging (C-Arm). The K-wire should be inserted considering that the centerline of the Hinge Plate will be placed approximately at 6.5mm (1/4") from the K-wire

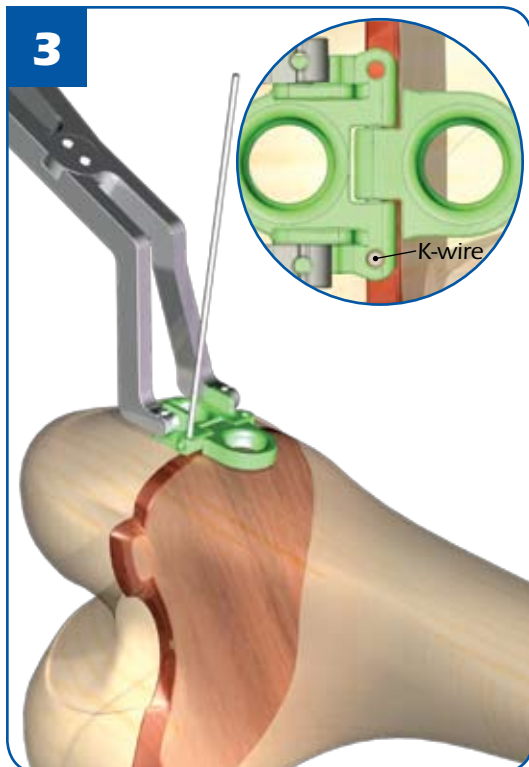

The Template is placed over the growth plate using the Croc Holder that is guided by the previously positioned K-wire.

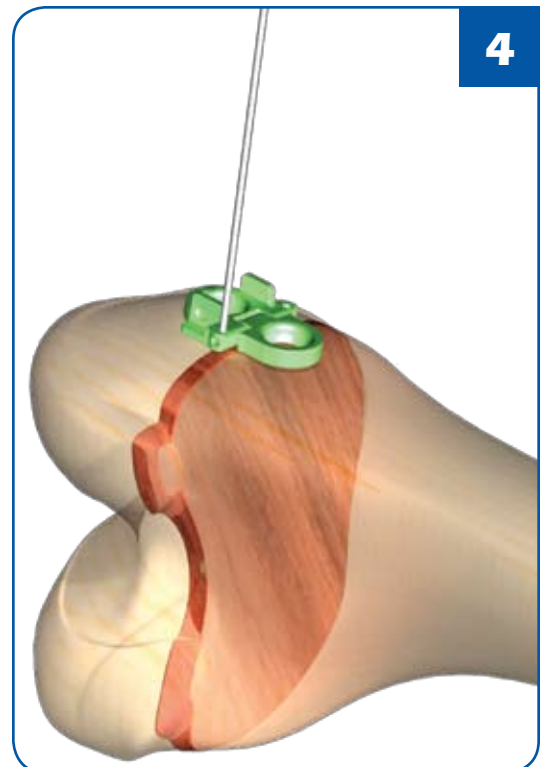

Release the Template and verify proper seating over bone surface and alignment with growth plate through C-Arm

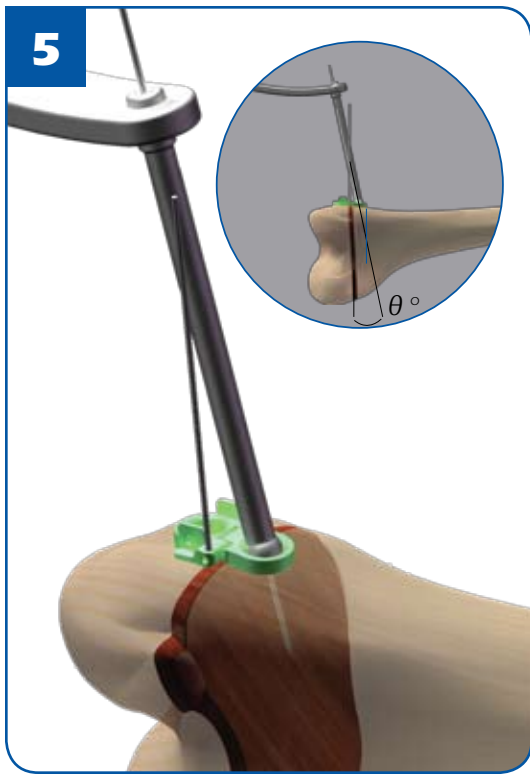

Define screw location by placing a second K-wire with the aid of the Dual Drill/Wire Guide at an angle away from the growth plate to avoid damage. Check position before drilling under G-Arm.

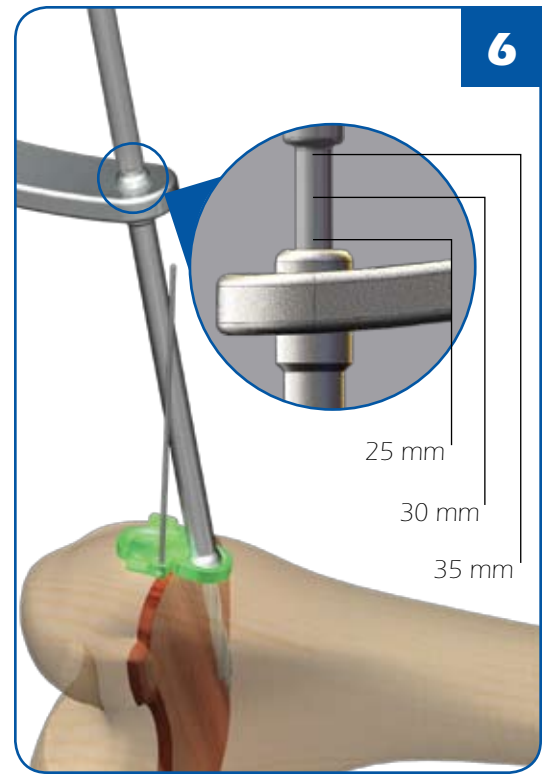

Using the cannulated drill bit, prepare screw hole to the depth indicated by the selected screw length.

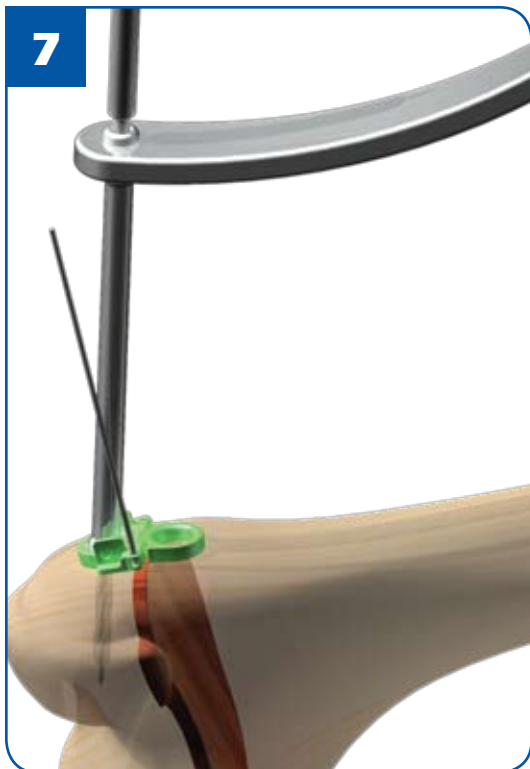

Once the first hole is drilled, proceed with same method for second hole

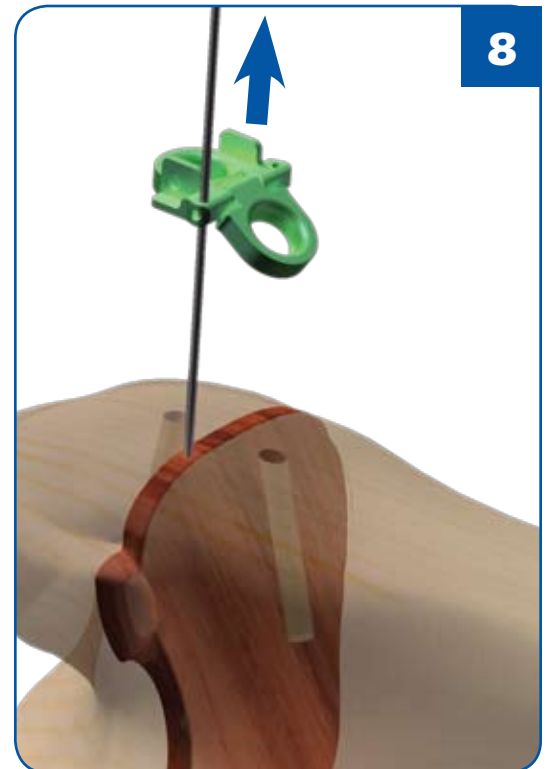

Having both holes perforated proceed to remove the Template.

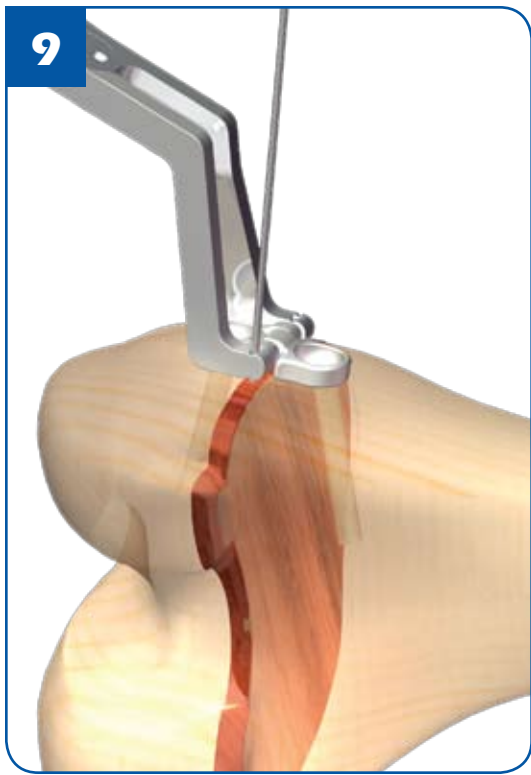

Proceed to position the Hinge Plate by using the Croc Holder assisted by the guiding K-wire.

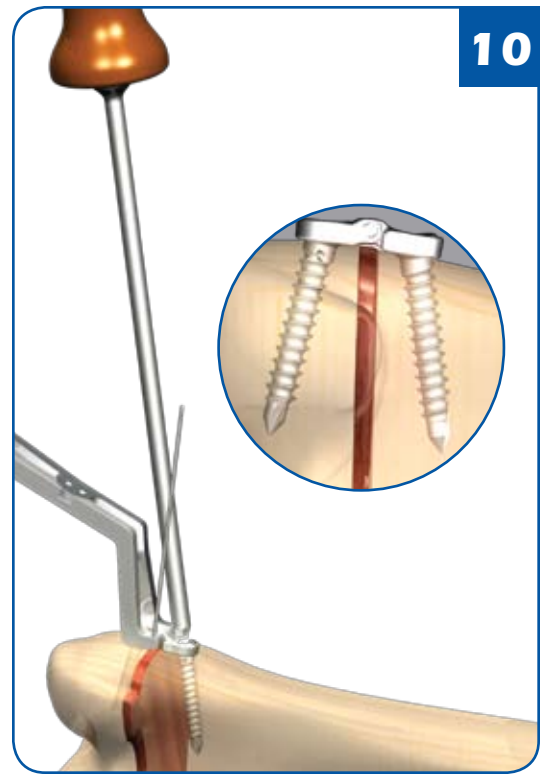

Once the Hinge Plate is secured, the procedure is concluded by removing the guiding K-wire followed by the Croc Holder. Assure proper implant seating over the bone surface, avoiding periosteal damage, and check screw final position before closing.

## Surgical Instrumentation

Part name	Catalogue
Croc Holder	HPH100
Dual Guide	HPDG110
Template 12 mm	HPT112
Template 16 mm	HPT116
Template 20 mm	HPT120
Drill 3.0 mm	HPD130
Guide Wire	HPW150
Screw Driver	HPSD160
Case	HPC200

